



Excavation and Trenching

Module Purpose

The purpose of this module is to explain steps in preparing for excavations, required duties of the competent person, determining soil classification, protective support systems, identifying safe alternatives to shoring, and basic emergency response procedures.

Time

60 minutes (10:40 - 11:40 am)
(A 10-minute break follows this module)

Objectives

Show slides 8.1 – 8.3.



Upon completion of this module, participants will be able to:

- Identify basic hazards associated with excavations and trenching
- Recognize the need for strict adherence to benching and shoring requirements.
- Recognize required responsibilities of the competent person
- Recognize the elements of soil stability, including the basic classifications for types of soil and rock
- Recognize types of systems used to protect workers from cave-ins in trenches and excavations through shoring, shielding and benching
- Determine basic emergency response procedures

**Materials and
Resources**

PowerPoint Slides: Module 8
Activity: Appendix 8-A
Sloping and Benching Options: Appendix 8-B

Module 8: Excavations and Trenching

Instructional Strategy and Course Content

Facilitator Notes

Lecture



1. What is the difference between a trench and an excavation? Show Slide 8.4.

2. Why are trenches and excavations so dangerous? Show slides 8.5 – 8.8..

3. What are stresses and deformations? Show slides 8.9 – 8.15.



Lesson

1. What is the difference between a trench and an excavation?

An excavation is any man-made cut, cavity, trench, or depression in an earth surface that is formed by earth removal. A trench is a narrow excavation (in relation to its length) made below the surface of the ground. In general, the depth of a trench is greater than its width, and the width (measured at the bottom) is not greater than 15 feet (4.6 m).

2. Why are trenches and excavations so dangerous?

A number of stresses and deformations can occur in an open cut or trench causing the earth to fall on anyone inside, leading to death from crushing and suffocation.

3. What are “stresses” and “deformations” and what causes them?

One example of a circumstance creating instability and possibly leading to a cave-in is an increase or decrease in moisture content in the soil, often caused by rain. The change in moisture affects the soil's cohesion or “how it sticks together.” As the soil becomes less cohesive, it is unstable. There are signals that may indicate that the soil is unstable.

Tension Cracks

Tension cracks usually form at a horizontal distance of 0.5 to 0.75 times the depth of the trench, measured from the top of the vertical face of the trench.

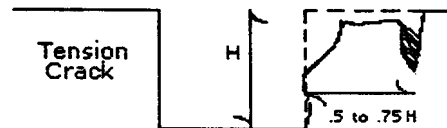

Sliding

Sliding or “sluffing” may occur as a result of tension cracks, where chunks of earth break away from the edge and fall into the trench or excavation.

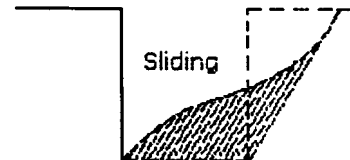

Toppling

In addition to sliding, tension cracks can cause toppling. Toppling occurs when the trench's vertical face shears along the tension crack line and topples into the excavation.

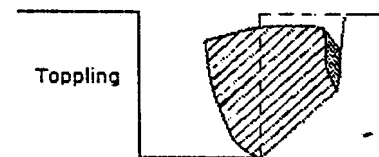

Subsidence and Bulging

An unsupported excavation can create an unbalanced stress in the soil, which, in turn, causes subsidence at the surface and bulging of the vertical face of the trench. If uncorrected, this condition can cause face failure and entrapment of workers in the trench.

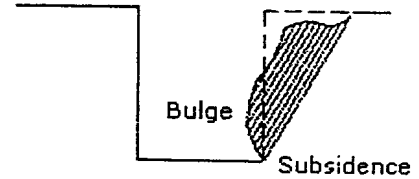

Heaving or Squeezing

Bottom heaving or squeezing is caused by the downward pressure created by the weight of adjoining soil. This pressure causes a bulge in the bottom of the cut. Heaving and squeezing can occur even when shoring or shielding has been properly installed.

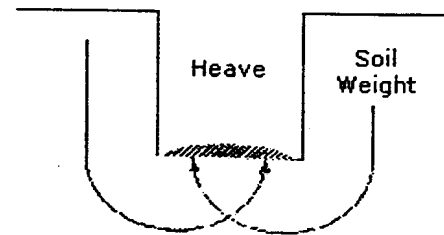

Boiling

Boiling is evidenced by an upward water flow into the bottom of the cut. A high water table is one of the causes of boiling. Boiling produces a "quick" condition in the bottom of the cut, and can occur even when shoring or trench boxes are used

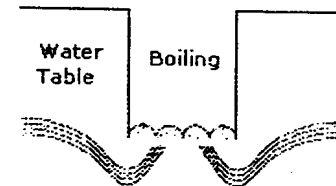

4. Are some types of soil more stable than others? Show Slides 8.15.



4. Are some types of soil more stable than others?

OSHA categorizes soil and rock deposits into four types:

- **Stable Rock** is natural solid mineral matter that can be excavated with vertical sides and remain intact while exposed.
- **Type A Soils** are cohesive soils with an unconfined compressive strength of 1.5 tons per square foot (tsf) (144 kPa) or greater. Examples of Type A cohesive soils are often clay, silty clay, sandy clay, and clay loam.
- **Type B Soils** are cohesive soils with an unconfined compressive strength greater than 0.5 tsf (48 kPa) but less than 1.5 tsf (144 kPa). Examples of other Type B soils are angular gravel, silt, and silt loam.
- **Type C Soils** are cohesive soils with an unconfined compressive strength of 0.5 tsf (48 kPa) or less. Type C soils include granular soils such as gravel, sand and loamy sand, submerged soil, soil from which water is freely seeping, and submerged rock that is not stable.

Activity



5. Identify the hazards in the video clip. Show slides 8.16 – 8.17; see Appendix 8-A

6. How can workers be protected when working in trenches or excavations? Show Slides 8.18 – 8.26.



Instructor Note: Show slides and/or bring soil samples to help participants understand the different types of soil and the systems need to protect workers in excavations.

5. Activity — Identify the Hazard

Identify the hazards in the video clip.

6. How can workers be protected when working in trenches or excavations?

There are several systems that can be used to protect workers from cave-ins in trenches and excavations. They are shoring, shielding and benching.

Shoring is the provision of a support system for trench faces used to prevent movement of soil, underground utilities and roadways. Shoring or shielding is used when the location or depth of the cut makes sloping back to the maximum allowable slope impractical. Shoring systems consist of posts, wales, struts, and sheeting.

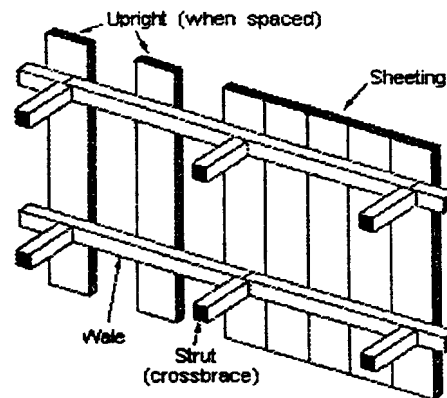

Shored walls are commonly made of timber, iron & aluminum.

- **Hydraulic Shoring**—The trend today is toward the use of hydraulic shoring, a prefabricated strut and/or wale system manufactured of aluminum or steel. Hydraulic shoring provides a critical safety advantage over timber shoring because workers do not have to enter the trench to install or remove hydraulic shoring. Other advantages of most hydraulic systems are that 1) they are light enough to be installed by one worker; 2) are gauge-regulated to ensure even distribution of pressure along the trench line; and 3) can be adapted easily to various trench depths and widths.

All shoring should be installed from the top down and removed from the bottom up. Hydraulic shoring should be checked at least once per shift for leaking hoses/cylinders, broken connections, cracked nipples, bent bases, and any other damaged/defective parts.

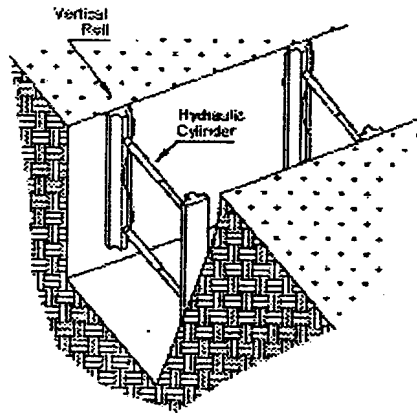

Vertical Aluminum Hydraulic Shoring (Spot Bracing)

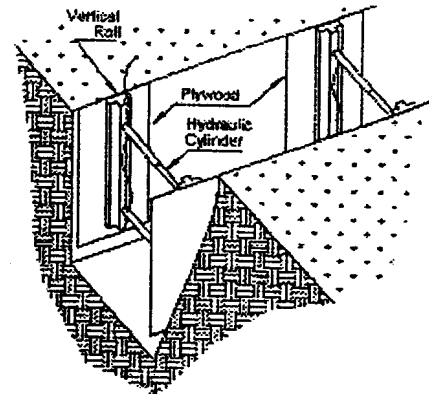

Vertical Aluminum Hydraulic Shoring (With Plywood)

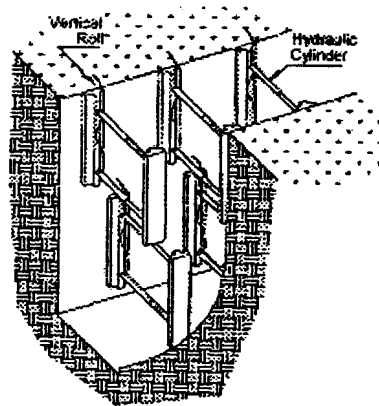

Vertical Aluminum Hydraulic Shoring (Stacked)

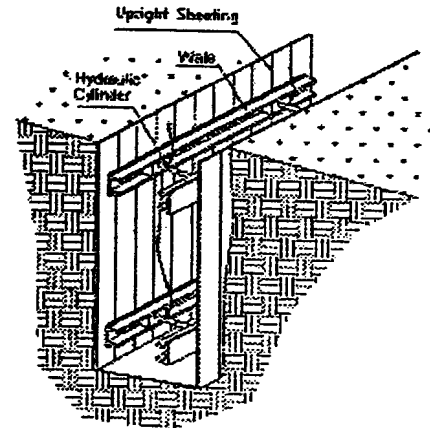

Aluminum Hydraulic Shoring Water System (Typical)

- **Pneumatic Shoring** —This system works in a manner similar to hydraulic shoring. The primary difference is that pneumatic shoring uses air pressure in place of hydraulic pressure. A disadvantage to the use of pneumatic shoring is that an air compressor must be on site. Examples include Screw Jacks and Single-Cylinder Hydraulic.

Shielding involves the use of protective the excavations to prevent earth from fall

- **Trench Boxes** are different from shoring because, instead of shoring up or otherwise supporting the trench face, they are intended primarily to protect workers from cave-ins and similar incidents.

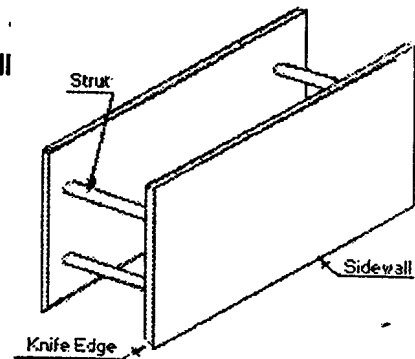

The excavated area between the outside of the trench box and the face of the trench should be as small as possible. The space between a trench box and the excavation side should be back-filled to prevent lateral movement of the box.

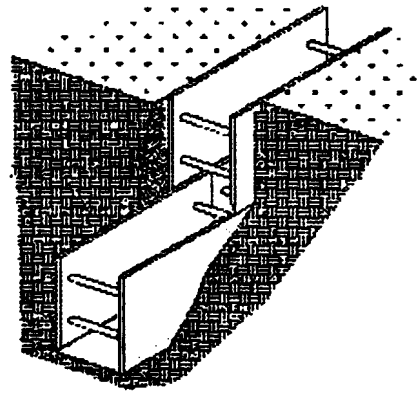

- **Combined Use**—Trench boxes are generally used in open areas, but they also may be used in combination with sloping and benching. The box should extend at least 18 in (0.45 m) above the surrounding area if there is sloping toward excavation. This can be accomplished by providing a benched area adjacent to the box.

Sloping and Benching require removal of earth from the edge of the excavation at an angle such that there is insufficient pressure on the soil at the edge to cause the top or edges to collapse. (See Appendix 8-B.)

- **Sloping**—The maximum allowable slopes for excavations less than 20-ft (6.09 m) is based on the SOIL TYPE and the vertical to horizontal ratio of the slope for that type of soil. The earth must rest according to the ratio without deformation.
- **Benching**—There are two basic types of benching: simple and multiple. The type of soil determines the horizontal to vertical ratio of the benched side. As a general rule, the bottom vertical height of the trench must not exceed 4-ft (1.2 m) for the first bench. Subsequent benches may be up to a maximum of 5-ft (1.5 m) vertical in Type A soil and 4 ft (1.2 m) in Type B soil to a total trench depth of 20-ft (6.0 m). All subsequent benches must be below the maximum allowable slope for that soil type. For Type B soil the trench excavation is permitted in cohesive soil only.

**TABLE 8-1
ALLOWABLE SLOPES**

Soil Type	Height/Depth Ratio	Slope Angle
Stable Rock	Vertical	90°
Type A Soil	¾ : 1	53°
Type B Soil	1 : 1	45°
Type C Soil	1 ½ : 1	34°
Type A (short-term) <i>(for a maximum excavation depth of 12 ft)</i>	½ : 1	63°

**Note: Excavations greater than 20 feet must be designed by a registered professional engineer.
See Appendix B for illustrated drawings.**

Facilitator Notes

7. What should be done with earth that is removed from the excavation? Show slides 8.27 – 8.30.



Lesson

7. What should be done with earth that is removed from the excavation?

Temporary Spoil—Temporary spoil (earth removed from the excavation or slope/bench) must be placed no closer than 2 ft (0.61 m) from the surface edge of the excavation, measured from the nearest base of the spoil to the cut. This distance should not be measured from the crown of the spoil deposit. This distance requirement ensures that loose rock or soil from the temporary spoil will not fall on employees in the trench.

Spoil should be placed so that it channels rainwater and other run-off water away from the excavation. Spoil should be placed so that it cannot accidentally run, slide, or fall back into the excavation.

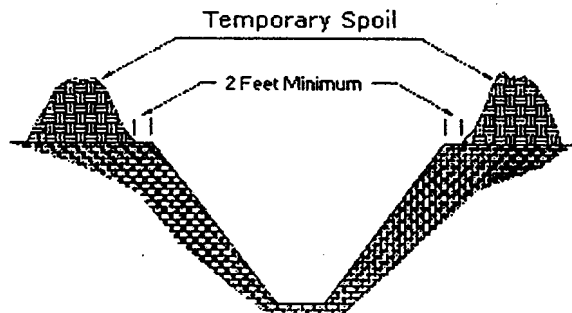

Permanent Spoil—Permanent spoil should be placed at some distance from the excavation. Permanent spoil is often created where underpasses are built or utilities are buried. The improper placement of permanent spoil (i.e. insufficient distance from the working excavation) can cause an excavation to be out of compliance with the horizontal-to-vertical ratio requirement for a particular excavation. This situation can usually be determined through visual observation. Permanent spoil can transform undisturbed soil to disturbed soil and dramatically alter slope requirements.

8. What considerations should be given to “bridges” over excavations? Show slides 8.31 – 8.32.



8. What considerations should be given to “bridges” over the excavations?

Surface Crossing Of Trenches—Surface crossing of trenches should be discouraged; however, if trenches must be crossed, such crossings are permitted only under the following conditions:

- When used, vehicle crossings must be designed by and installed under the supervision of a registered professional engineer
- When walkways or bridges are used for foot traffic. These structures shall:
 - have a safety factor of 4;
 - have a minimum clear width of 20 in (0.51m)
 - be fitted with standard rails; and
 - extend a minimum of 24 in (.61m) past the surface edge of the trench

9. How should one enter and exit a trench or excavation? Show slide 8.32 (still).



9. How should one enter and exit a trench or excavation?

Ingress And Egress—Access to and exit from the trench require the following conditions:

- Trenches 4 ft or more in depth should be provided with a fixed means of egress.
- Spacing between ladders or other means of egress must be such that a worker will not have to travel more than 25 ft laterally to the nearest means of egress.
- Ladders must be secured and extend a minimum of 36 in (0.9 m) above the landing.
- Metal ladders should be used with caution, particularly when electric utilities are present.

Facilitator Notes

10. Should I be concerned about vehicles and equipment operating near an excavation? *Show slide 8.33.*



11. Are there other safety considerations in trenching and excavations? *Show slides 8.34 – 8.37.*



12. Do trenching and excavations operations require a competent person? *Discuss.*



Lesson

10. Should I be concerned about vehicles and equipment operating near an excavation?

The following steps should be taken to prevent vehicles from accidentally falling into the trench:

- Barricades must be installed where necessary
- Hand or mechanical signals must be used as required
- Stop logs must be installed if there is a danger of vehicles falling into the trench
- Soil should be graded away from the excavation; this will assist in vehicle control and channeling of run-off water.

11. Are there other safety considerations in trenching and excavation operations?

Often in excavation operations, there is a tendency to fixate on the excavation hazards and sometimes overlook other safety problems that arise when workers are below grade level. Special care must be taken to protect workers in excavations from the following hazards (which are covered in more detail in other modules):

- Confined spaces and hazardous atmospheres
- Overhead loads
- Nearby construction equipment and vehicles

12. Do trenching and excavation operations require a competent person?

Yes. A competent person is required for many aspects of trenching and excavation operations. Competent Person-required operations include:

- Daily inspections for evidence of a situation that could result in a possible cave-in, indications of failure of protective systems, hazardous atmospheres, or other hazardous conditions
- Design of structural ramps that are used solely by employees as a means of access or egress from excavations
- Structural ramps used for access or egress of equipment shall be designed by a competent person qualified in structural design, and shall be constructed in accordance with the design
- Use of water removal equipment to control or prevent accumulation

Facilitator Notes

Lesson

- When excavation work interrupts the natural drainage of surface water (such as streams), diversion ditches, dikes, or other suitable means and steps must be taken to prevent surface water from entering the excavation and to provide adequate drainage of the area adjacent to the excavation

13. Elicit additional questions and summarize. *Slide 8.38.*

13. Question and summary period.

? Questions ?

14. Transition to Module 9.

14. Transition to prepare participants for Module 9.

Identify the Hazard – Trenching & Excavations

Objective: This short activity will allow participants to view a brief video clip and the list the hazards that they have observed in the clip. It is designed to serve as a discussion tool for the instructor to emphasize the need for strict adherence to benching and shoring requirements when working in trenches and excavations.

Materials:

- Power Point Slides 8.16 & 8.17. (Double click the image to begin video.) The Instructor may want to play the clip several times to allow students to watch it carefully.

Time: 5 minutes

Activity: Instruct the students that they are to watch the video clip and identify all the hazards that they observe. (You may also ask them to identify safety practices as well.) After reviewing the clip, ask students to share their observations with the class.

Important points to identify are:

- Workers must stay in protected areas at all times
- Ladders must extend 3 feet above the edge of the trench
- Ladders must be inside the protected area
- Spoil piles must be back at least two feet

Sloping and Benching Options

